

**X-POLE<sup>®</sup>**  
LEADERS IN POLE & AERIAL FITNESS

# INSTRUCTION MANUAL

**X-POLE<sup>®</sup>**

***X-Stage***

**Portable Exercise and Dance Stages**



Congratulations on buying an X-STAGE/X-STAGE LITE. They represent a revolution in portable podium stages and have been designed for portability, ease-of-use and high stability. They are the world's first collapsible circular stages and feature both 'Static' and 'Spinning' modes as standard. The team at X-POLE have spent a significant amount of time researching, designing and developing the X-STAGE. We want the X-STAGE to be the world's leading Exercise and Dance Podium, if it's not; we want to understand why not! At X-POLE we thrive on positive criticism and suggestions! So contact us (details on the back cover) if you have any comments or suggestions on how to improve the product.

## BEFORE USING YOUR POLE

Mis-using a pole can be dangerous, not only to the user but also to anyone close to the pole. The use of a dance pole is always at the user's discretion, and it is the **user's** responsibility to check the pole is installed correctly & safely before use.

Pole Exercise is extremely physical and uses muscles that you will not have used before and therefore if you are not warmed up; muscle damage, strains and injury can occur. Before using the X-STAGE it is mandatory to **warm up** and, after use, **cool down**.

It is highly recommended that before you use your X-STAGE you purchase a suitable DVD to learn the basic moves. Never try moves beyond your ability without an instructor. If at any time whilst using your pole you feel uncomfortable, your muscles hurt, or you are short of breath – take a break. Always rest between moves & exercise sensibly, if you experience any health issues, seek medical advice.

The X-STAGE is designed for use by a single person.

Have fun with your X-STAGE.

**The X-POLE Team.**

## WHAT TO WEAR

### **Clothing**

When it comes to clothing – less is best (unless you have purchased a Silicone Pole). So try to keep your arms and legs uncovered. Pole work needs the friction created by skin contact, so T-Shirts, Crop Tops & Shorts are best. However, you must feel comfortable so wear what you feel relaxed in (tracksuit bottoms, etc.) even though this may mean you are unable to do some of the pole moves properly because of grip.

### **Footwear**

Again comfort is essential. Bare feet (recommended), dance shoes, or trainers can be used but trainers have high friction, so a trainer with a smooth as possible sole is recommended.

### **Oils and Lotions**

NEVER use oils and/or lotion on your hands or body prior to using your pole. This is very DANGEROUS. The oil can transfer onto the pole making it slippery and impossible to hold and this could cause you or someone using the pole after you to have a serious accident.

# **CRITICAL INFORMATION - PLEASE READ THIS BEFORE STARTING INSTALLATION**

To get the best from your X-STAGE – with SAFETY being the utmost priority – it is extremely important that you READ & FOLLOW the Instruction Manual from beginning to end and most importantly, understand it!

Follow the simple but explicit instructions in this manual to get the best results from your X-STAGE.

## **Safety is a priority at all times.**

If you have ANY questions – before you assemble, install or use your X-STAGE – contact your point of purchase or see the X-STAGE section on the website ([www.xpole.com](http://www.xpole.com) – first select your region, then search for the X-STAGE section).

VERTICAL LEISURE LTD, X-POLE INTERNATIONAL, X-POLE US INC, THEIR DISTRIBUTORS, SALES PERSONS OR ANY OTHER PERSONS OR ASSOCIATED COMPANIES **CANNOT** BE HELD RESPONSIBLE FOR ANY DAMAGE TO PROPERTY OR INJURY TO PERSONS OR THIRD PARTIES DURING THE USE OF THIS PRODUCT.

BY REMOVING THE X-STAGE FROM ITS PACKAGING AND/OR ANY USE OF THE PRODUCT CONFIRMS ACCEPTANCE OF THE ABOVE WARNINGS AND THE USER'S RESPONSIBILITY IN USING THE PRODUCT.

### **IF YOU DO NOT ACCEPT THE TERMS SET OUT ABOVE THEN:**

**DO NOT** ATTEMPT TO ASSEMBLE, INSTALL OR USE THE PRODUCT.

Contact your point of purchase to arrange a return & refund (shipping costs may still apply). The product must be returned unused & in its fully packaged state.



**CAUTION: Never undo any of the screws unless you are explicitly told to do so in the instruction manual.**

**WANT A QUICKER WAY TO ASSEMBLE YOUR X-STAGE?**

**WHY NOT SCAN THE CODE TO GO DIRECT TO OUR YOUTUBE CHANNEL TO WATCH THE INSTALLATION VIDEO.  
Search for the 'X-STAGE' Installation Video.**



## X-STAGE / X-STAGE LITE CONTENTS



**TIP:** We recommend that you leave the parts in their carry cases until you need them, as this lessens the risk of accidental damage or loss. The X-Stage/X-Stage Lite is supplied in 4 purpose-made carry cases for safety, storage and transportation purposes.

### X-Stage - Carry Case 1

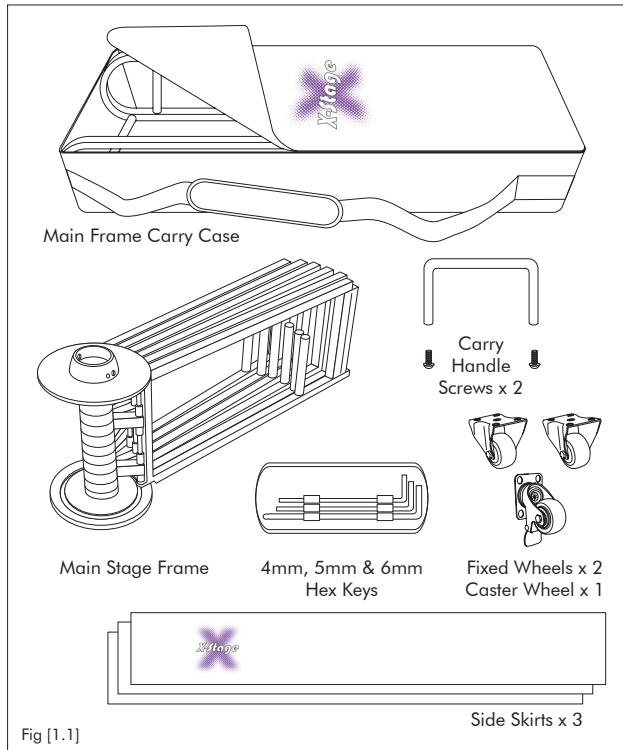

### X-Stage Lite - Carry Case 1

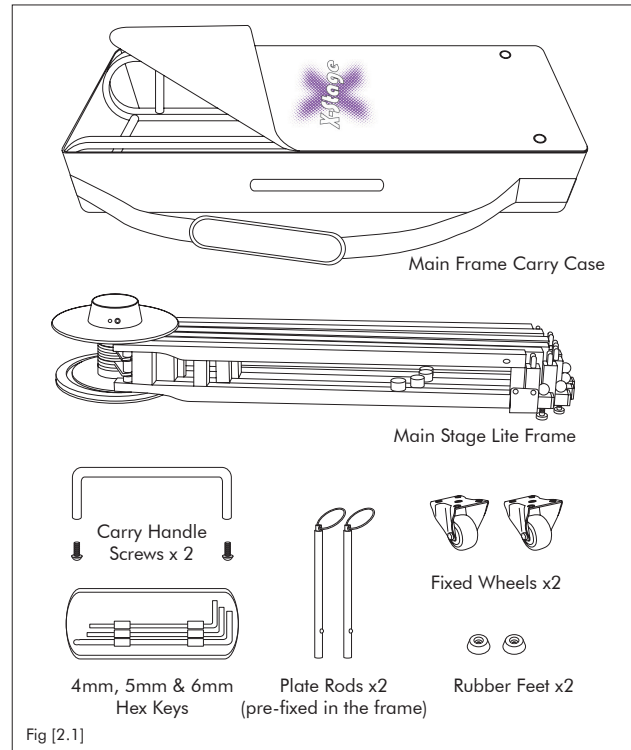

### X-Stage - Case 2

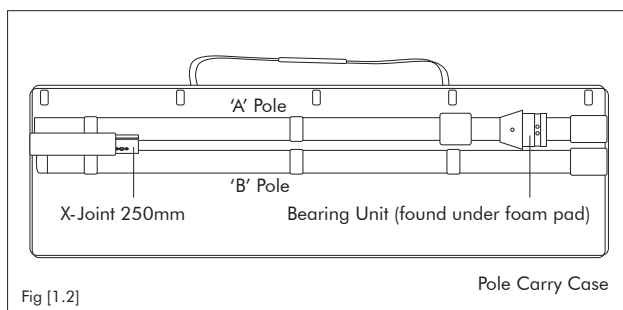

### X-Stage Lite - Case 2

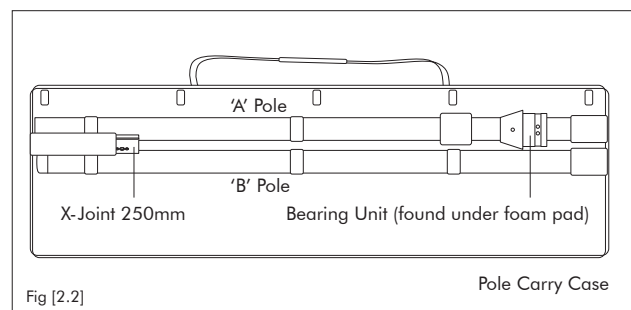

### X-Stage - Case 3

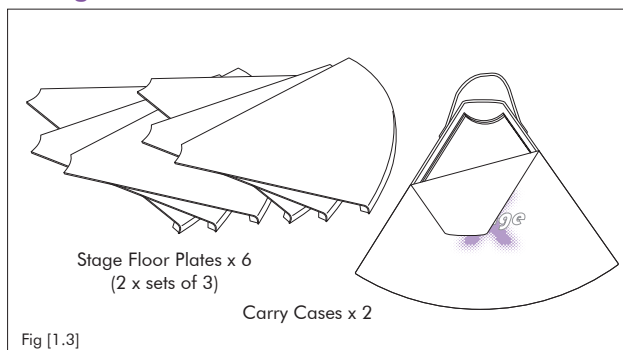

### X-Stage Lite - Case 3

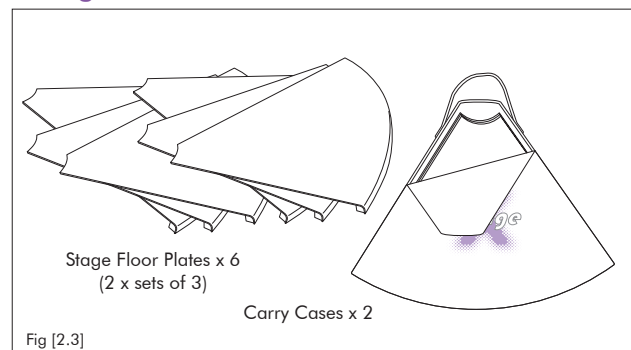

## CONTENTS – CARRY CASE

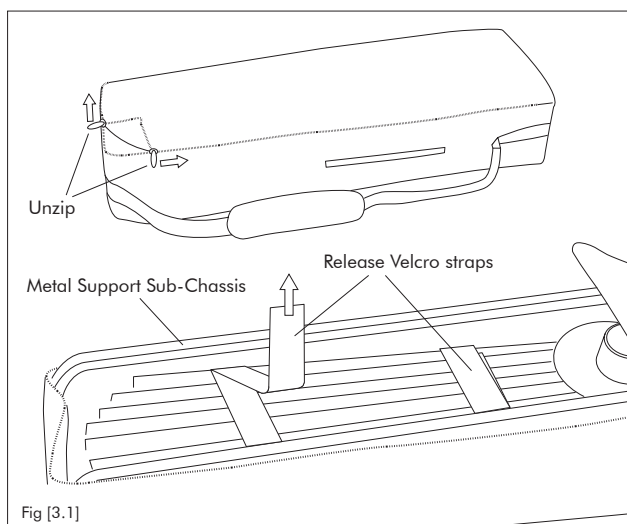

Fig [3.1]

Start by unzipping the Main Frame Carry Case that contains the Main Stage Frame. This is secured with Velcro straps inside the carry case on a metal support sub-chassis. This carry case also incorporates the Sub-Chassis, Handle Bar, Wheels, Side Skirts (X-Stage only), Rubber Feet and Plate Pegs (X-Stage Lite only), along with the hex screws and hex keys to secure them.

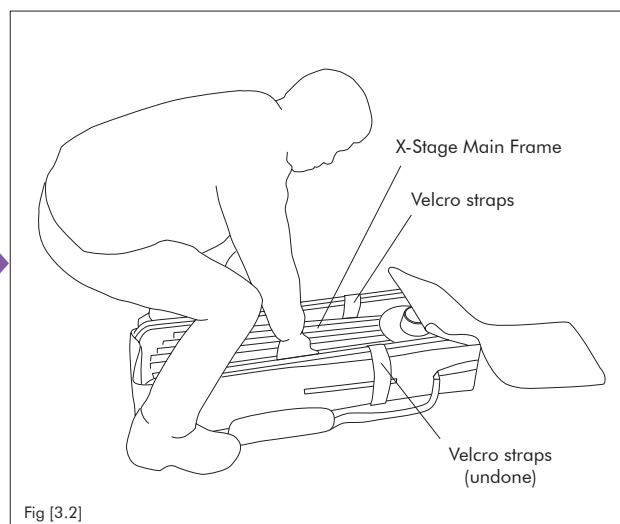

Fig [3.2]

First, remove the Velcro straps securing the Main Stage Frame to the Sub-Chassis. Stand with your feet either side of the Carry Case, bending your knees slightly and keeping your back straight. Position your hands either side of the Main Stage Frame as shown and carefully lift it and slide out of the Main Frame Carry Case, placing it to either the left or right side of the Carry Case for now.



**CAUTION:** The Main Stage Frame is the heaviest single component of the X-Stage/X-Stage Lite, so care must be taken not to injure yourself when removing or handling. Please ensure your knees are slightly bent and your back is straight when lifting.



**TIP:** Note how the velcro straps attach and which way round the Main Stage Frame is positioned for when you eventually come to pack this away. Take a photo for reference. Putting the Main Stage Frame back into its Carry Case and securing it to the Sub-Chassis is the reverse of the removal procedure.

## ASSEMBLY - CARRY CASE HANDLE BAR

With the Main Stage Frame out of the Carry Case, attach the Handle Bar to the top of the Carry Case's sub-chassis with hex screws provided, using the smallest (4mm) of the three hex keys.

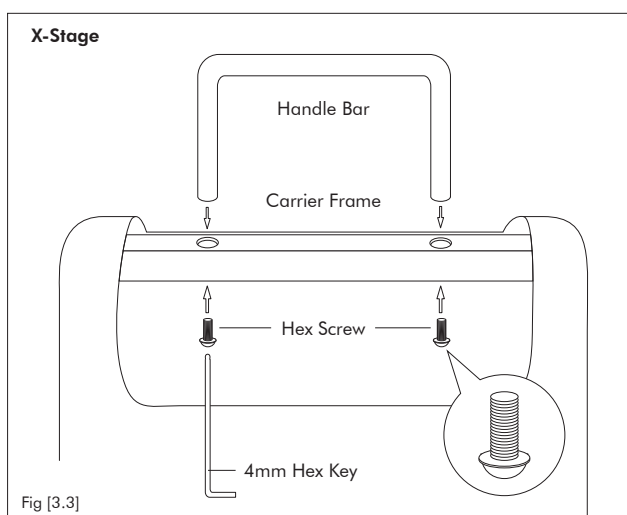

Fig [3.3]

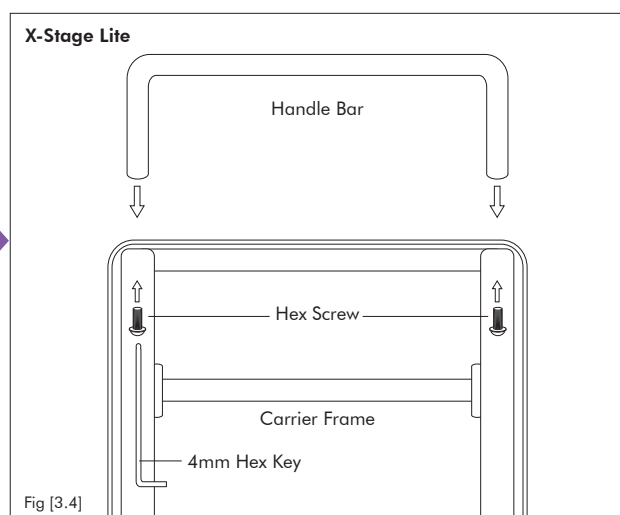

Fig [3.4]

## ASSEMBLY - CARRY CASE WHEELS & (Rubber Feet - X-Stage Lite only)

Locate the pre-fixed screws on the underside of the Carry Case's sub-chassis where the wheel assemblies attach. Secure the wheels using the - 4x hex screws (pre-fixed) per wheel, using the 4mm hex key. The wheel assemblies have elongated slots in them to allow some movement on the sub-chassis frame. Position both wheels equally before tightening the hex screws.



**TIP:** Easiest method to attach the wheels is to remove just one pre-fixed screw, very loosely attach the wheel (turn the screw only 4-5 rotations) then remove the other screws and install them.

To attach the rubber feet, locate the pre-fixed screws in the Carry Case's sub-chassis where the rubber feet attach. With the 4mm hex key, remove the hex screws, position the rubber feet then secure the rubber feet using the hex screws. If there is a thin web of rubber over the holes in the 2x rubber feet (X-Stage Lite only). To open them up, simply push one end of the securing hex key through to create a hole when installing.

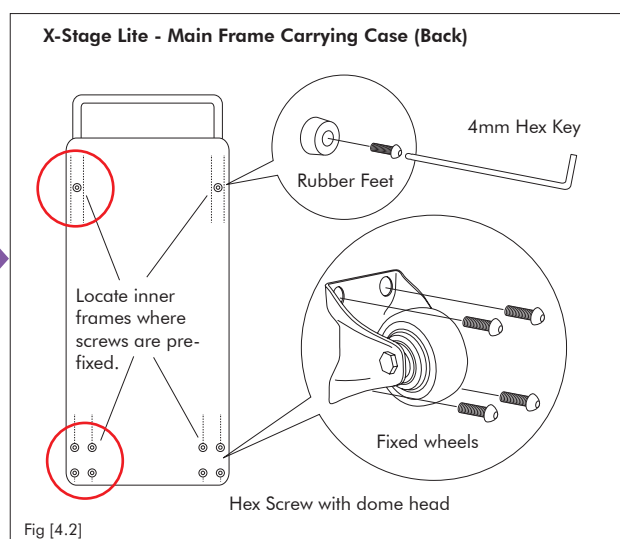
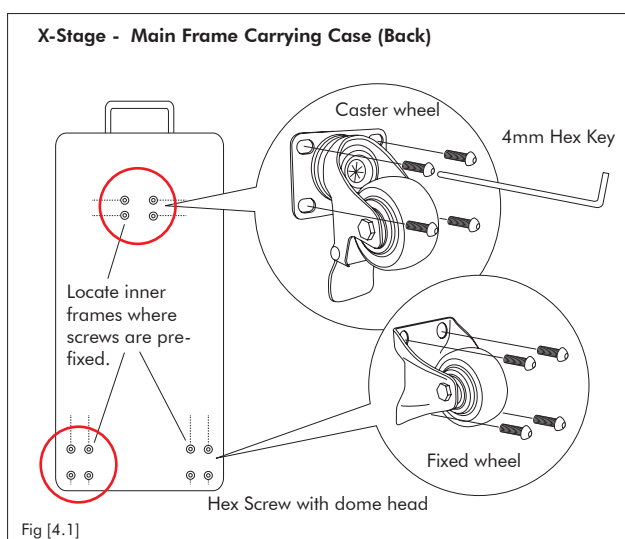

## Screws Installation

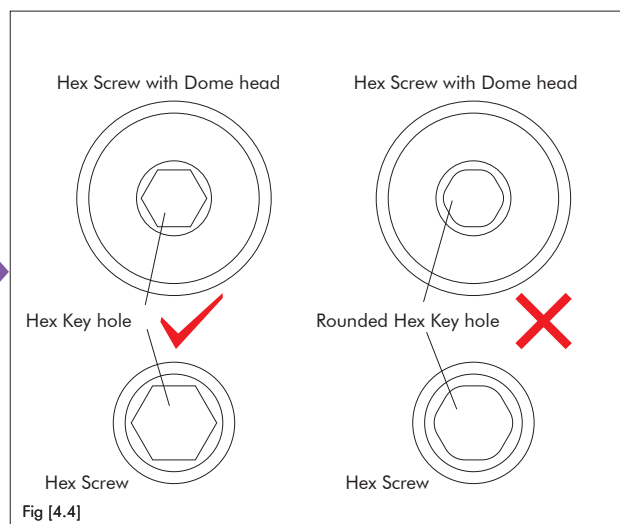
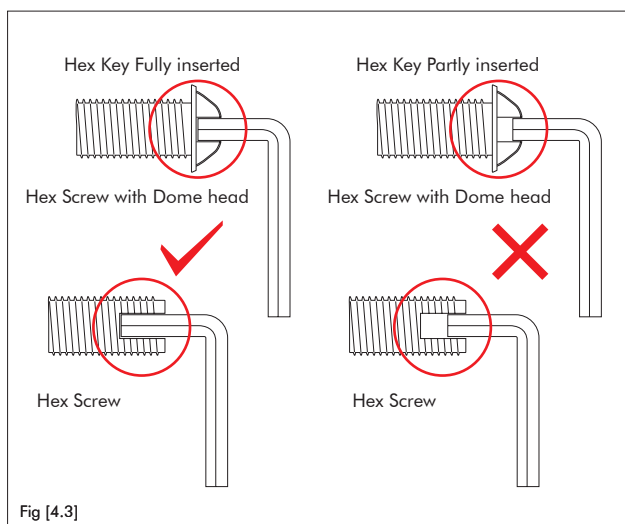

**CAUTION:** You must ensure that a hex key is fully inserted into the hex screw before attempting to tighten the screw (Fig.4.3). Partial insertion will damage the screw holes (round them) (Fig.4.4) making it difficult to tighten, or more importantly, undo them. If you damage any screws - please make sure they are replaced. Spare parts can be purchased from your main dealer/local stockist/point of purchase.

## (X-Stage Lite only)

The X-Stage Lite Sub-Chassis is fitted with 2 x Extendable Rods that allows the 2 x Floor Plate carry cases to be positioned on the Main Stage Frame Carry Case for transport. The Extendable Rods are push-fitted and secure to the sub-chassis by means of spring-loaded ball catches. They are supplied installed under the case cover. To re-install, you will need to remove them from the sub-chassis. Unzip and pull back the case cover, then take hold of the rings and pull the rods out (Fig.5.1), zip the cover back up and install the rods through the rings in the case (Fig.5.2).

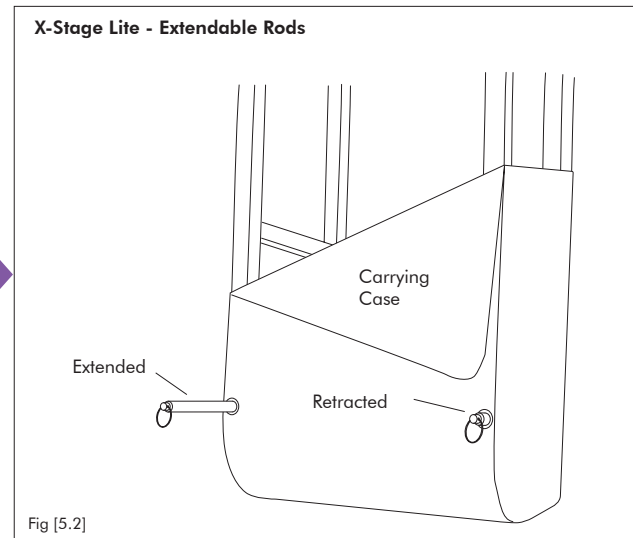
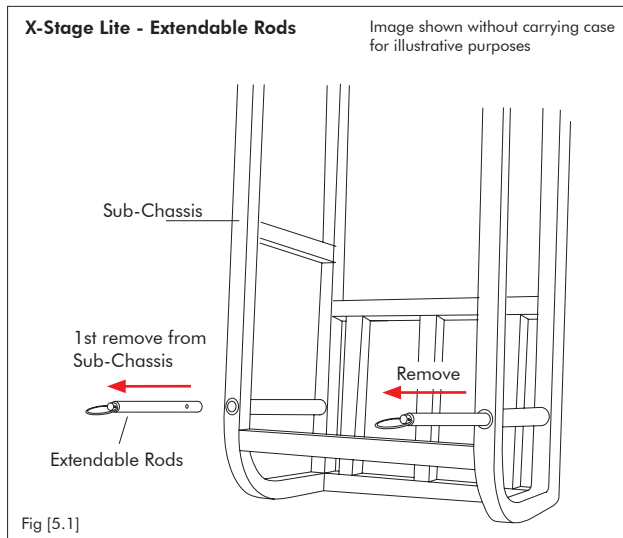

You can now extend the Rods when required to carry one or both of the Floor Plate carry cases (Fig.5.3). Push them back into the Sub-Chassis when not required.

The X-Stage Lite sub-chassis features an additional carry handle that can be accessed through the side of the carry case as shown (Fig.5.4).



**TIP:** It is always best to carry the main frame using this solid handle when not transporting Floor Plates.

Now that the Handle Bar, Wheels and Rubber Feet have been secured to the Sub-Chassis, it is ready to be transported.

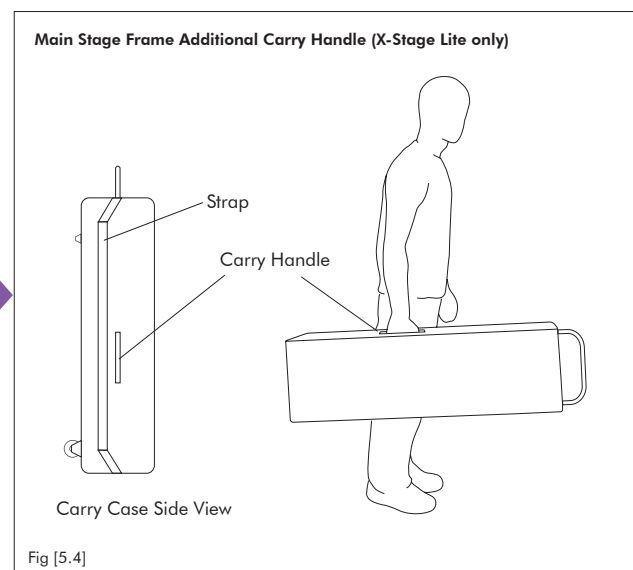
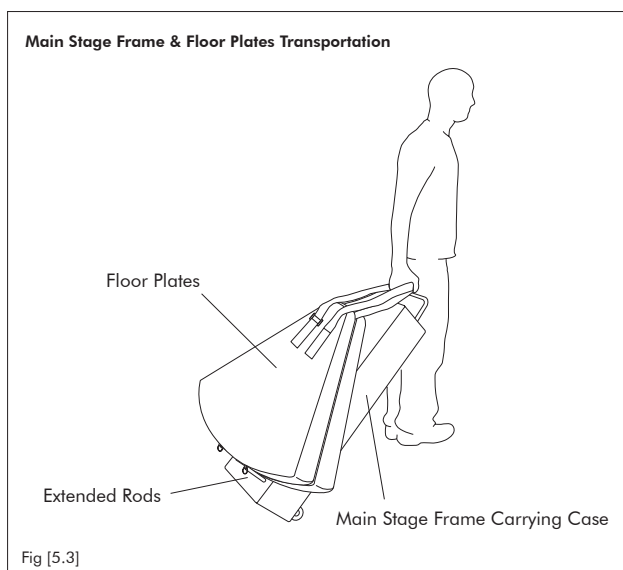

## FINDING A SUITABLE AREA TO DANCE/EXERCISE

To use the X-Stage/X-Stage Lite properly and safely, you need to be able to fully rotate around the pole with your arms outstretched and NOT be able to touch/hit anything whilst doing so (Fig.6.1). This will require an area greater than the diameter of the stage itself all around the stage. Therefore, the required area should be a minimum of 3m in diameter.

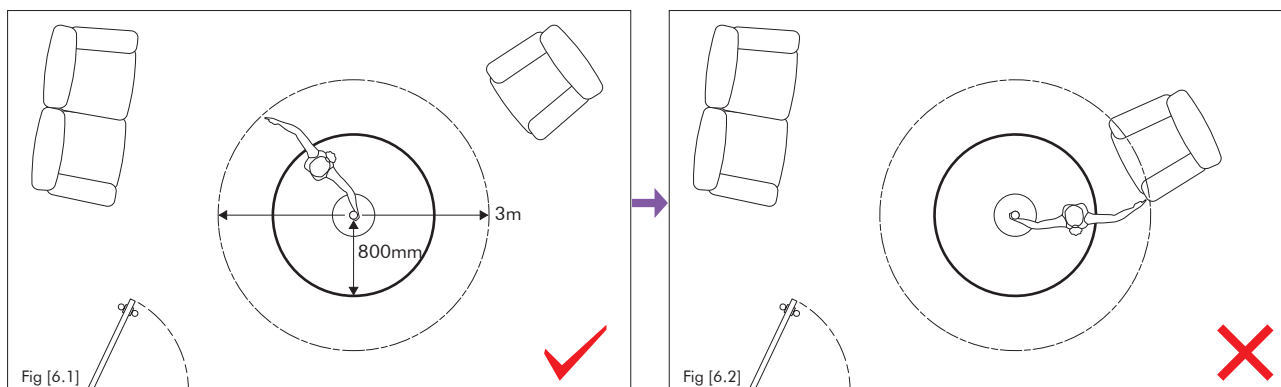

**TIP:** Dance moves can be carried out in a smaller space than detailed above by more experienced users.

## HEIGHT CALCULATION – ‘STANDARD FORMAT’

You should measure the ceiling height where you intend setting up your X-Stage/X-Stage Lite before assembly to ensure that it is within the ‘Standard Format’.

A key point with any pole is to get the maximum height of workable (usable) pole. The X-Stage/X-Stage Lite is supplied with an overall height of 3m (10’). This is called the ‘Standard Format’. The usable pole height for the X-Stage and X-Stage Lite is 2.68m (8’8”) and 2.89m (9’5”) respectively, when standing on the stage floor.

However, you need to allow for an additional 125mm (4.9”) to enable the ‘B’ Pole to be attached to the ‘A’ Pole, as this is the depth of the protruding X-Joint. Therefore, a ‘Standard Format’ X-Stage or X-Stage Lite, will require an overall ceiling height of 3.2m (10.5’) or higher.

If the ceiling is lower - shorter extensions can be purchased to use instead of the B-Pole provided

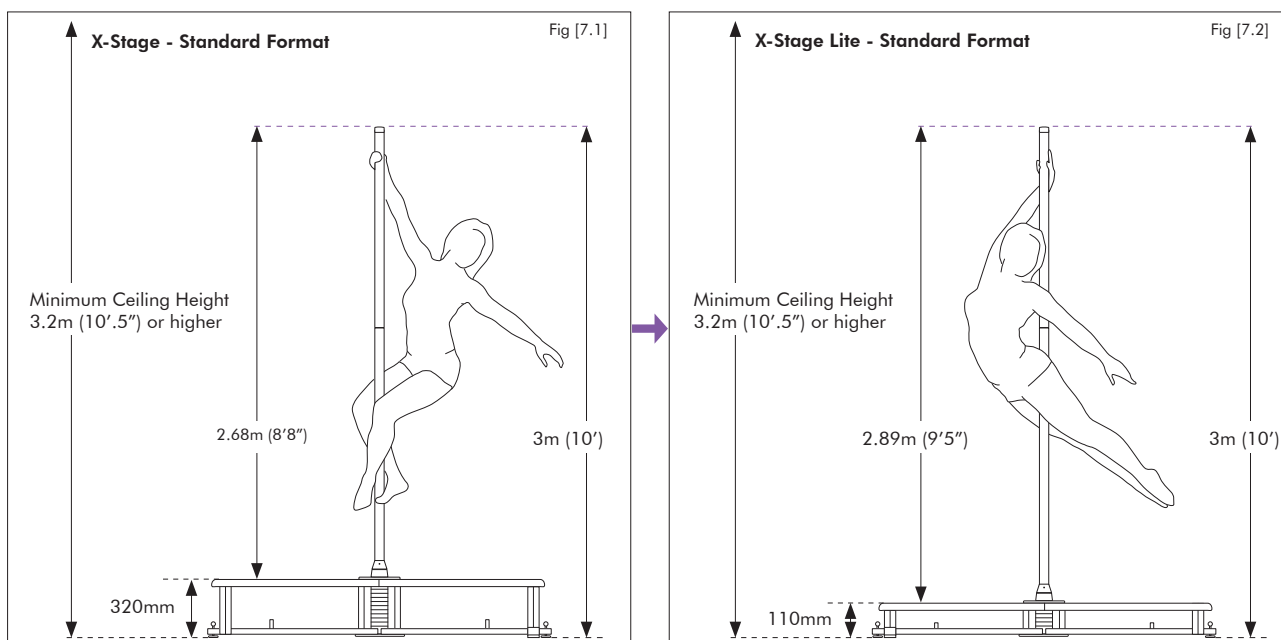



## ASSEMBLY OF MAIN STAGE FRAME

The Main Stage Frame is built up of 6 sub-frames that fan out to form a star structure. Position the Main Stage Frame in the centre of the dance/exercise area; ensure the assembly is the correct way up (Fig.8.1).

Locate Sub-Frame No.1 the one secured with screws top & bottom to the plates so that it cannot move. As you fan out the base to form a star shape, lift each sub-frame so that it does not drag on the floor (Fig.8.2).

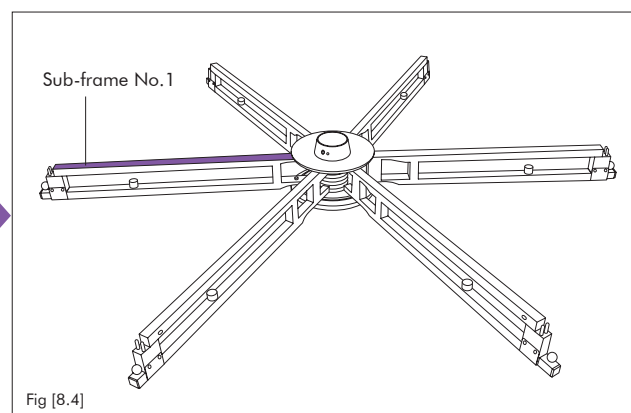
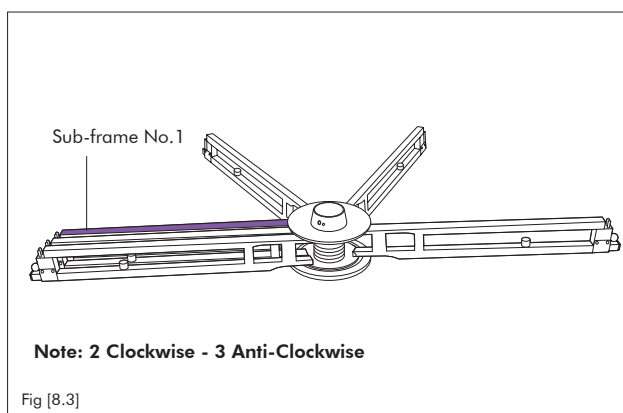
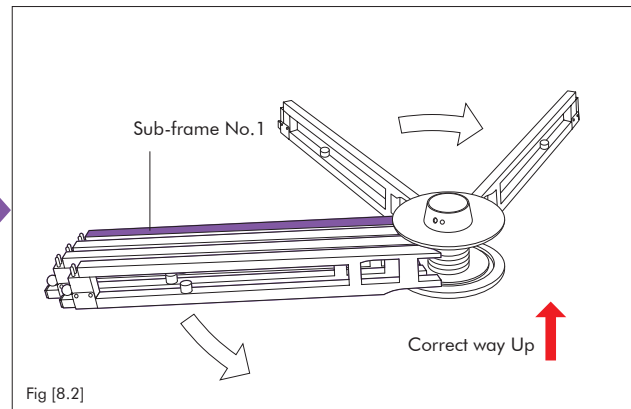
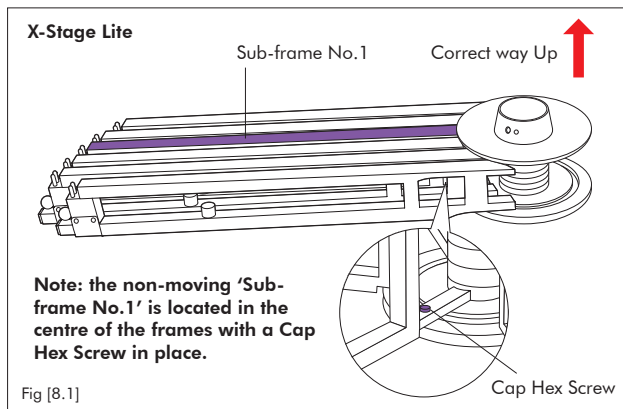

**TIP:** The legs fan out from Sub-Frame No.1 clockwise or anti/counter-clockwise, it does not matter which direction you choose. However, when dismantling, the moving sub-frames should always be folded back towards the Sub-Frame No.1.

## FITTING THE FLOOR PLATES



**CAUTION:** Be sure to remove all packaging material from the Floor Plates before you attempt to fit them to the Main Stage Frame.

If you examine one of the Floor Plates, you will see that there are two Spring Catches on its underside, located at each corner of the longer curved surface. Test the operation of the Spring Catches (Fig.9.1) before assembling to the Main Stage Frame. Lay the stage plate down on its face, then rotate the pin arm till it is vertical and the pin will move outwards. Each spring catch is spring loaded so that when you release it (turn it through 90 degrees), a pin will stick out of the edge of the floor plate and remain sticking out until you re-secure it. This is a safety feature to ensure that the Spring Catches do not accidentally retract in use, releasing the Floor Plates. The Spring Catches insert into the Floor Plate Locating Pin Holes (Fig.9.2) – together these are designed to secure each floor plate to the Main Stage Frame.

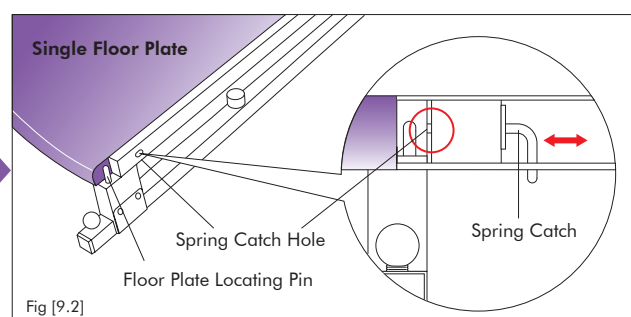
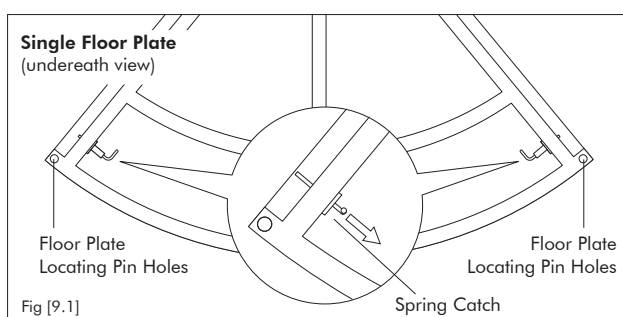

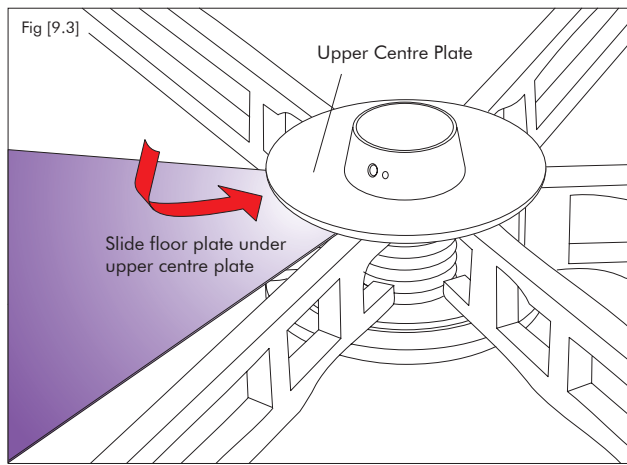

For the purpose of this illustration, we are working in an anti/counter-clockwise direction, but you can assemble in a clockwise direction if you prefer, it does not matter which. However, you must start at Sub-Frame No.1 and continue in the same direction.

To fit a floor plate, position the end with the smallest curve towards the Main Stage Frame, with the left edge over Sub-Frame No.1 (the one secured with a hex screw to the base plate). The smaller end of the Floor Plate will slide under the Upper Centre Plate (Fig.9.3).

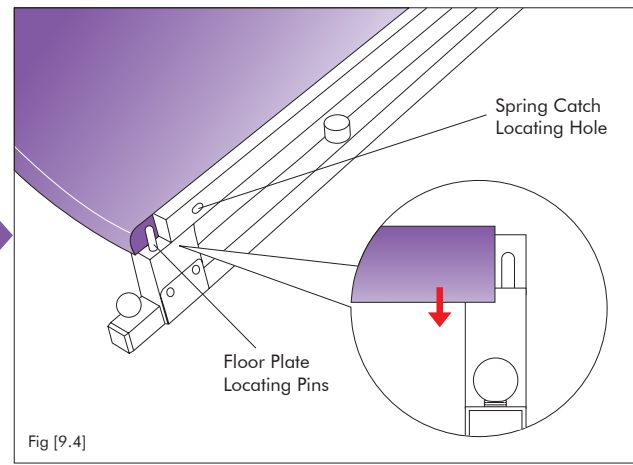

Whilst retracting the spring catch with one finger lower the other end of the Floor Plate onto the locating pin on the sub-frame. Ensure the pin is inserted into the hole in the floor plate. For the first few installations it may be necessary to stand on the edge of the floor plate (allowing the pins to engage).

Now position the next Sub-Frame so that its Locating Pin lines up with the Locating Pin Hole on the Floor Plate, lower the Floor Plate into position and release the spring catch.

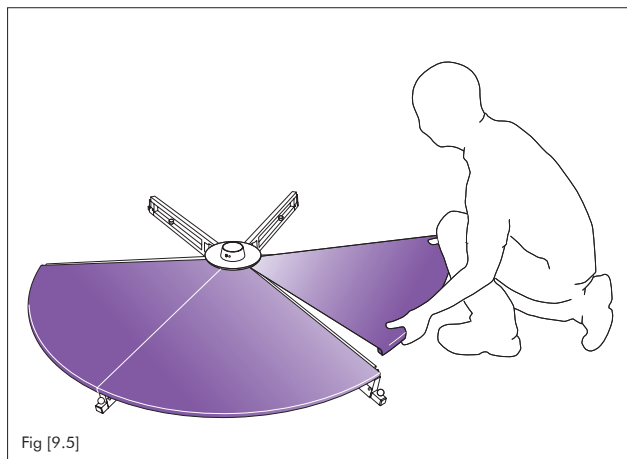

Continue to fit the remaining Floor Plates in the same way, securing each with its Spring Catches before moving onto the next. Once the plate is in place, if it does not completely engage, stand on the corner of the Floor Plate and exert force. Once the Floor Plates are on, make sure the Stage legs are parallel to the Floor Plates. To check whether the plates are secure, try lifting them out of place – if correctly installed, they will not disengage.

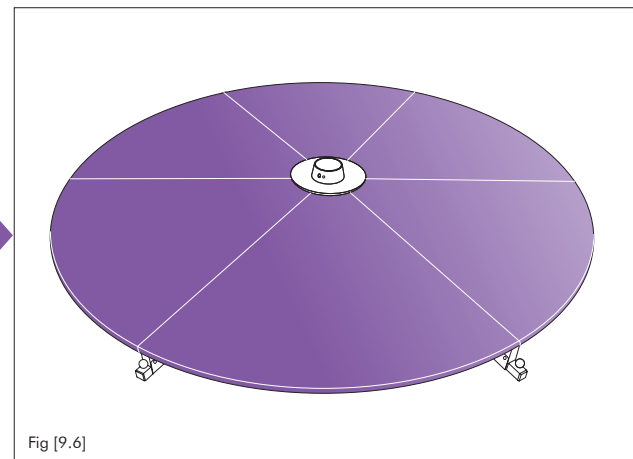

You have now completed the Main Frame assembly.

Disassembly of the Floor Plates is the reverse of the assembly procedure.



**CAUTION:** As each Floor Plate is quite heavy, please take extra care when lowering them into position and take adequate steps to ensure that you do not injure yourself when doing so. When fitting, keep your back straight and your knees slightly bent at all times.



**TIP:** We recommend you keep all packaging material contained inside the Floor Plate carry cases so that you can better protect the Floor Plates in transit.

## POLE ASSEMBLY & INSTALLATION

The Pole is made of four parts, the 'A' Pole, a Bearing Unit that attaches to it, the 'B' Pole and an X-Joint. The 'A' and 'B' poles are connected using the X-Joint (Fig. 10.1).

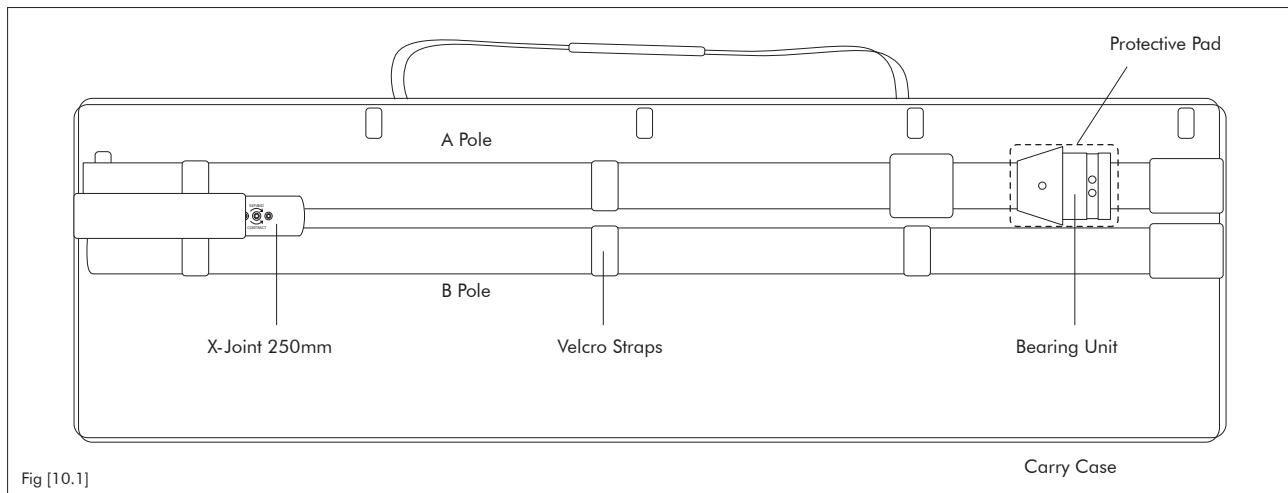

The Bearing Unit must be treated with great care and steps should be taken to ensure it is not dropped or knocked. Remove the band securing the bearing unit first. It is important to understand the Bearing Unit's operation as this will help when assembling and disassembling the pole.

The Bearing Unit has two sections; an upper angled section (the cone) with 3x M8 hex screws and a lower flat section (Bearing Body) which has a slot for positioning the bearing unit.

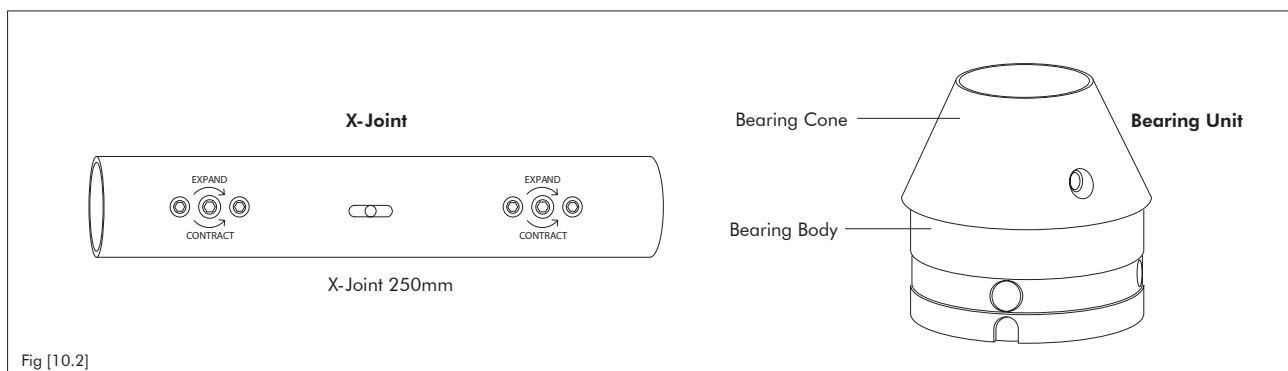

The cone upper angled section supports the pole and is secured to the 'A' Pole with the 3x M8 hex screws. These hex screws are used to adjust the pole's position in the Main Stage Frame assembly.

The lower flat section bearing body is the part that inserts into the stage's Bearing Carrier on the Upper Centre Plate and also supports the pole. This section includes 2x M10 hex screws which set the 'Static/Spinning' modes of the X-Stage/X-Stage Lite. When these 2x hex screws are tightened it is in 'Static' mode. When the hex screws are loosened, the pole is in 'Spinning' mode.

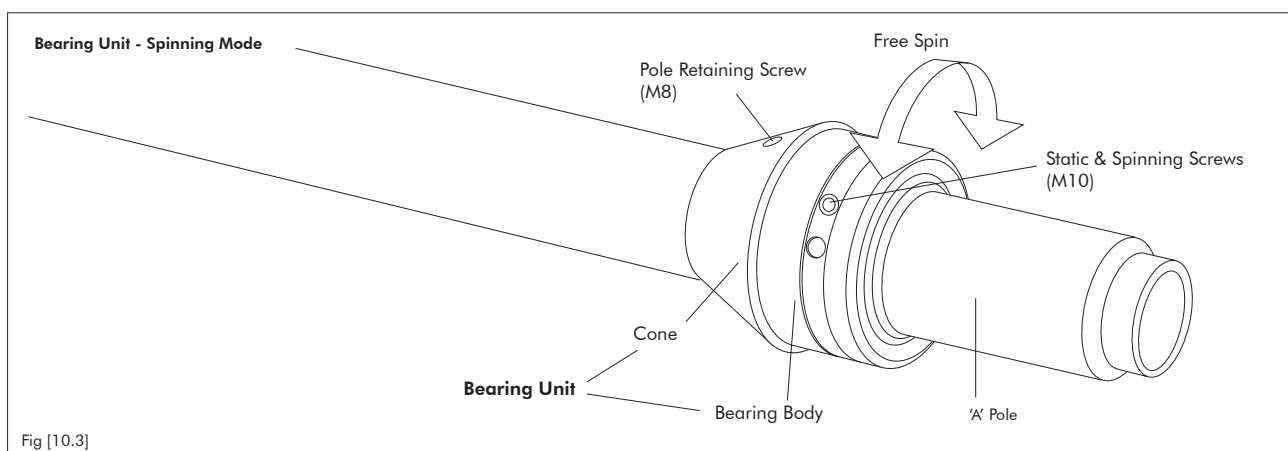

## POLE INSTALLATION - MOUNTING THE 'A' POLE & BEARING UNIT

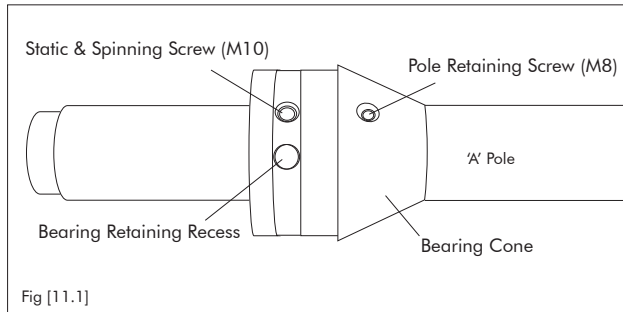

When you open your stage pole set – the 'A' POLE, the pole tube that goes into the stage base, will already have the 'bearing unit' (Fig.11.1) attached to the pole. It will NOT be locked in position. Please remove the elastic rubber band holding the bearing unit in place.

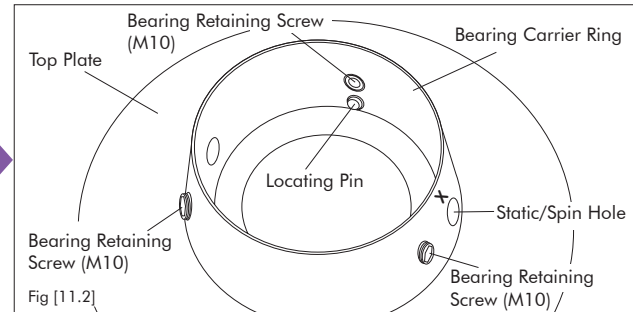

Next, look inside the Bearing Carrier Ring on the stage top plate and you will see a pin sticking out. Now look at the Bearing unit on the pole and you will see a slot. The pin on the Bearing carrier engages into the slot on the bearing unit (Fig.11.2)

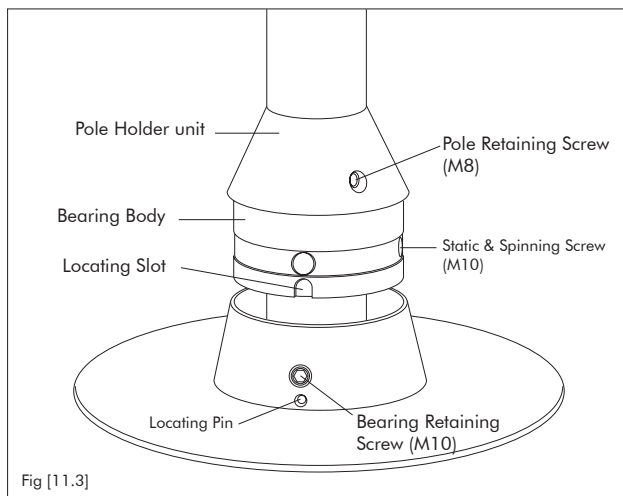

Whilst holding the bearing unit, take care that it does not slide off the end of the pole, insert the 'A' POLE into the stage base ensuring the bottom of the pole is firmly seated in the bearing at the bottom of the base.

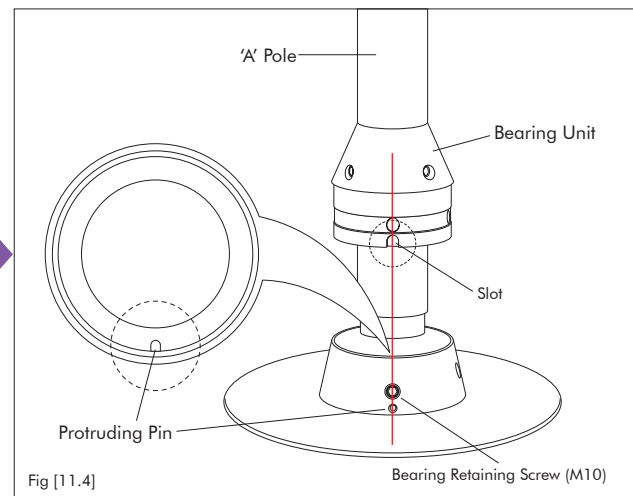

Whilst inserting the 'A' Pole and Bearing Unit into the Main Stage Frame, you must keep as upright and vertical as possible so that the pole locates correctly into the lower bearing in the Main Stage Frame.

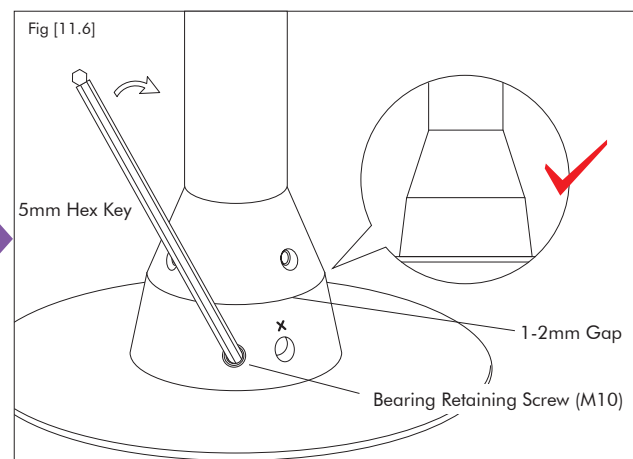
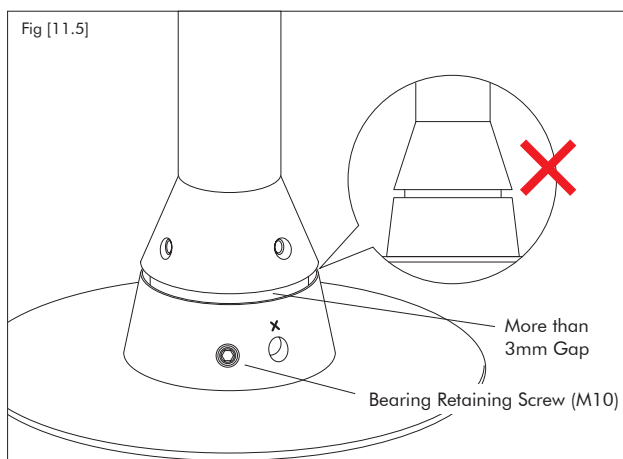

Ensuring the bearing unit is firmly seated (Fig.11.6), tighten the Bearing Retaining (3 x M10) Screws firmly (using the 5mm Hex Key) – ensure that your bearing unit is tightened into the bearing carrier. Tighten progressively – first lightly tighten each screw – then re-tighten all three firmly. (Replacement screws can be purchased from your local X-Pole agent).

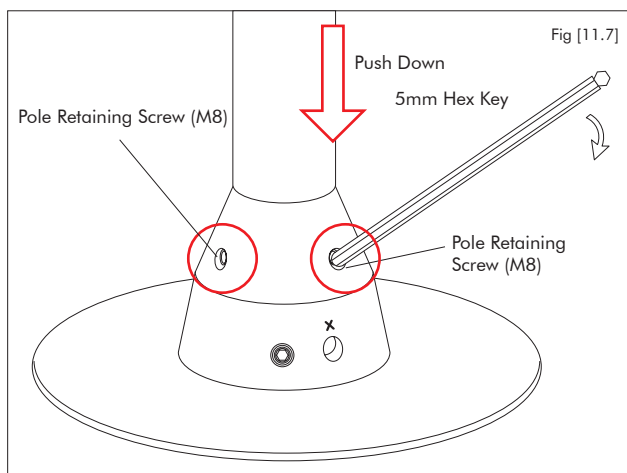

Next, pushing firmly down on the pole, ensure it is seated properly in the pole core - secure the 'A' POLE in place by tightening the 3 x M8 (Pole retaining screws using the 4mm Hex Key) in the 'Pole Holder unit'.

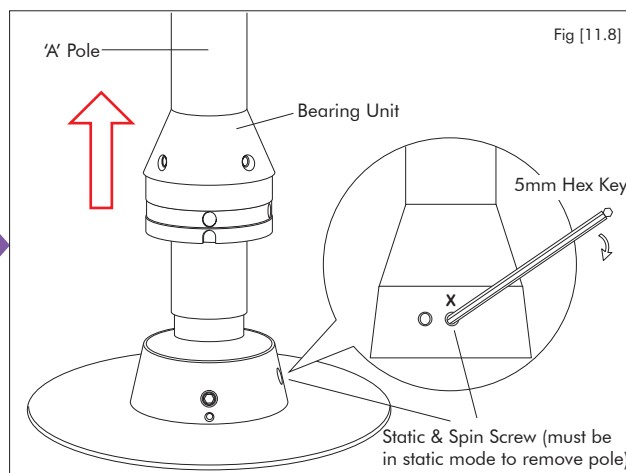

**IMPORTANT:** When dismantling, leave the complete bearing unit attached to your 'A' POLE. It is critical to set your pole to 'STATIC' mode prior to removal. If it is in spinning mode, the pole cannot be removed.



**TIP:** Prior to every use, make sure the screws are tight.

## Getting to know your X-JOINT

The X-STAGE includes the very latest in pole joint technology, the X-Joint. This joint is simple, easy to use, very strong and stable. Just follow these simple operational instructions to ensure the joint is properly locked.

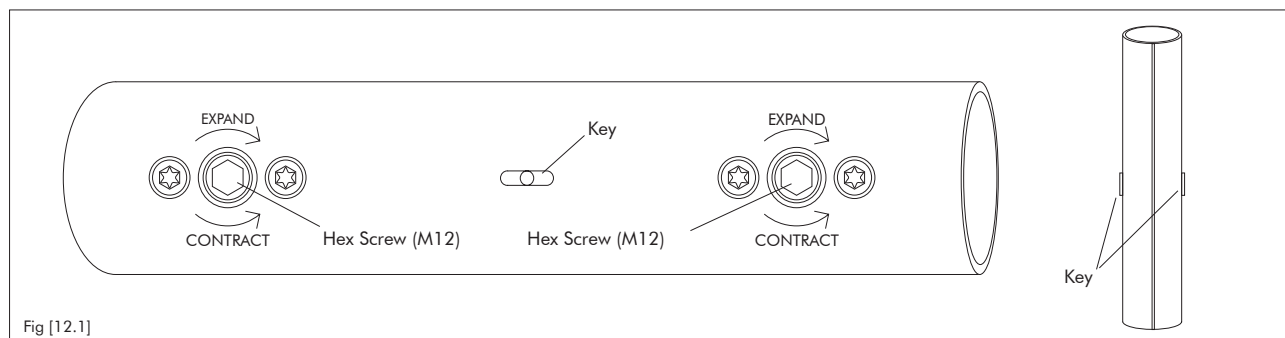

The X-Joint expands and locks the pole tubes together. The joint expansion is done by inserting the hex key, through holes in the pole tubes into the hex screws and turning the key clockwise.

The markings on the tube show the direction to turn the hex key. Clockwise to expand/tighten and Anti/Counter-Clockwise to contract/loosen. It is very important to remember this as when the tubes are in the pole these markings are covered and cannot be seen.

At the centre on either side of the joint is a Key. This Key slots into corresponding rounded slots at the ends of the pole tubes. These slots must go over the keys. The keys stop the pole tubes from rotating.

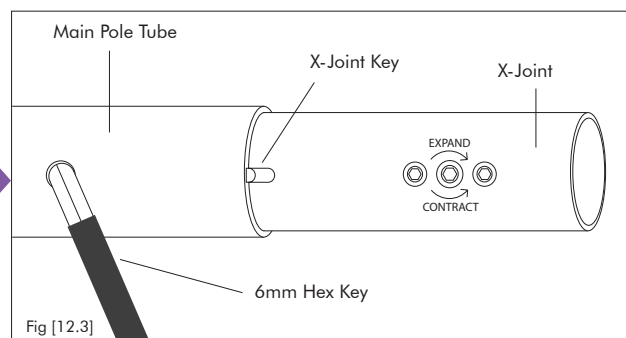
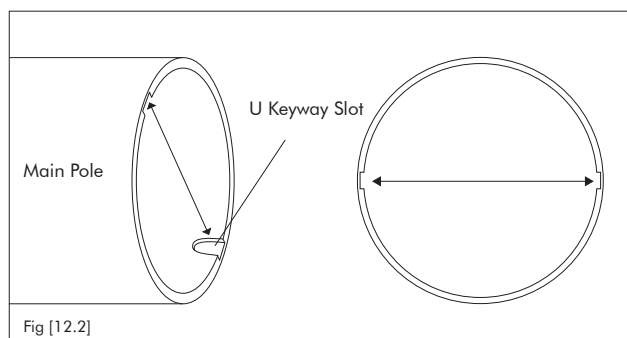

## Using the X-Joint to install the Pole Tubes

At the top of the 'A' Pole, you will see a hole on the outside and two rounded slots on the inside of the pole. To install the X-Joint simply slide one half into the A-Pole, ensuring the 2 x keys on the joint locate fully into the corresponding U slots in the tube. When inserting the X-Joint make sure that the large locking screw on the X-Joint aligns with the hex key hole in the pole tube otherwise you will not be able to insert the hex key. **DO NOT TIGHTEN NOW.**

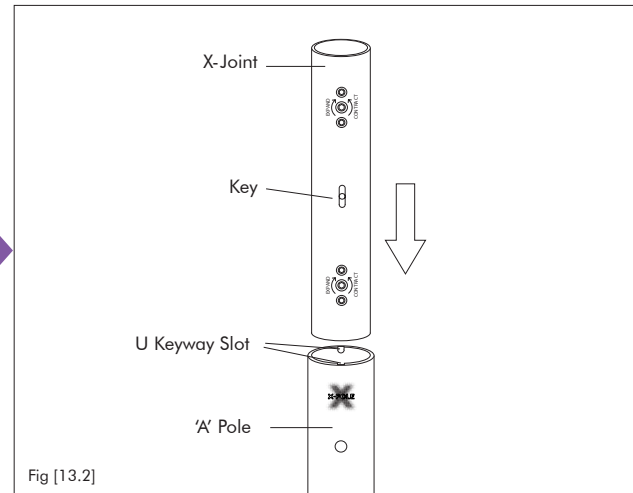
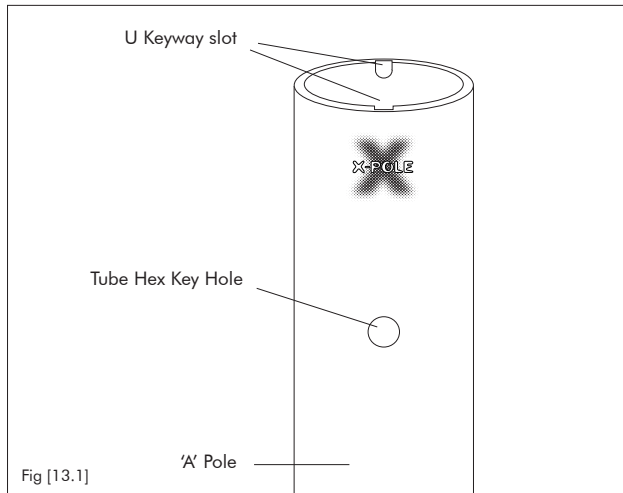

Next, take the 'B' Pole and slide it onto the X-Joint, checking the 'A' and 'B' Poles butt together. Take care to ensure that the hole in the 'B' Pole is positioned in line with the X-Joint's hex screw. Once properly joined, there should be a smooth transition between the 'A' and 'B' Poles. Now that the Poles are joined, you can begin to 'TIGHTEN' the X-Joint, 1/2 a turn at a time, alternating between the hex screw in the 'A' Pole, then the 'B' Pole, until the X-Joint has sufficiently expanded and locked the two poles securely together.

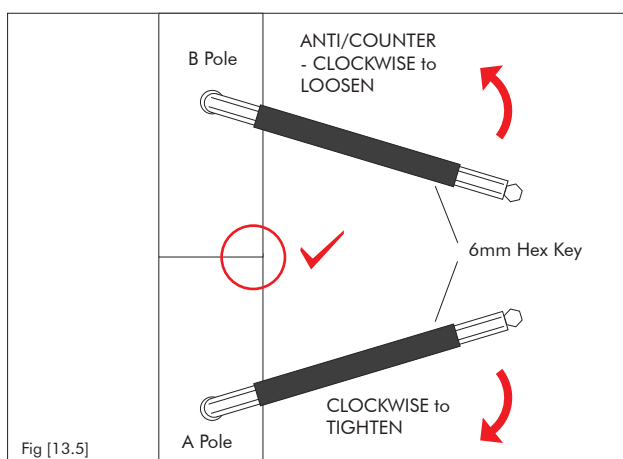
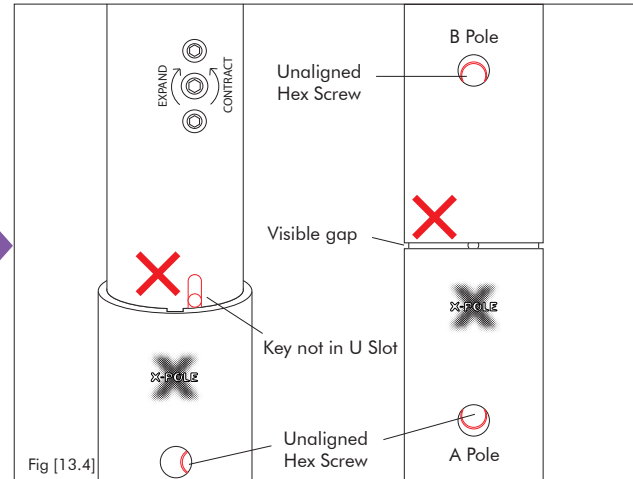
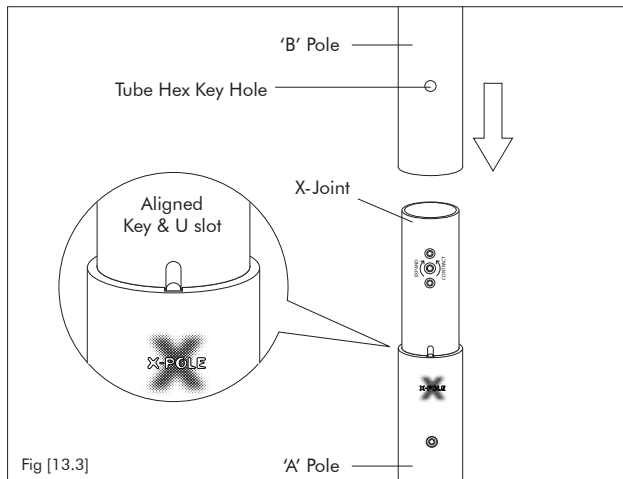

It is important to tighten the locking screws progressively, alternating the screws, so that the joint expands evenly, otherwise one side may not expand fully and the pole tube joints may not lock fully tight.

To undo the X-Joint - turn both hex screws 'anti/counter-clockwise'. Undo screws until the Hex Key moves freely and remove the X-JOINT.

## MAIN STAGE - FLOOR LEVEL SCREW ADJUSTERS

At the end of each of the 6 sub-frames is a Screw Adjuster with a 'Ball' top. Screw the adjuster clockwise to extend and counter-clockwise to retract. The Screw Adjusters have silicone pads that help prevent them slipping on floor surfaces.

The adjuster feet are there to level out uneven floors and to tension the stage thus reducing pole movement – we strongly recommend the floor level screw adjusters being used in all instances as this will ensure that your stage has minimum movement. After the pole installation is complete, lift each leg slightly, pull out the legs so that the Screw Adjuster can be undone with 30% of the screw thread being used. Do this for all 6 feet. Shake the pole to see whether there is any movement - if one/or more side rises, apply further screw adjustment to this/these side(s). Once there is minimum movement and the entire stage feels level - all feet have been stabilised correctly.

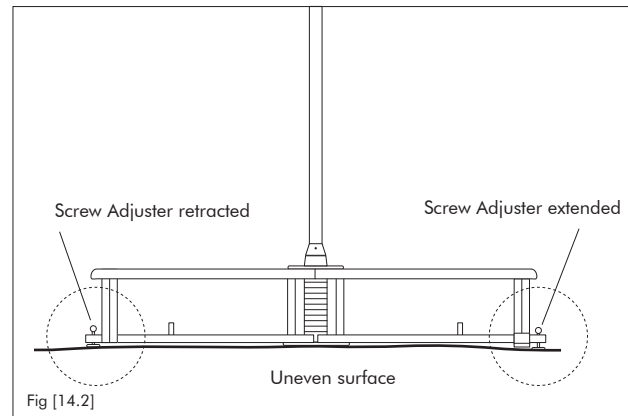
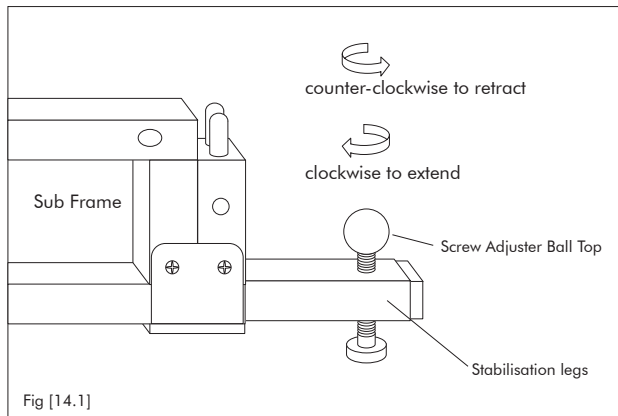

## MAIN STAGE - STABILISATION LEGS (X-STAGE/X-STAGE LITE)

To extend the legs, slightly lift the Stage's sub-frame and pull on the Screw Adjuster's ball top. The Stabilisation Leg will extend out of the Sub-Frame. Continue pulling the Stabilisation Leg until you hear a 'click' as the Leg's spring-loaded press-stud pops out of the hole near the end of the sub-frame and locks the Stabilisation Leg in place. Repeat this process for the remaining Stabilisation Legs until all 6 are locked in place. Now adjust the Screw Adjusters to ensure the Stage is stabilised. Adjust so that there is pressure on all the Stabilising Legs.

To retract the Stabilisation Legs, first retract all Screw Adjusters fully, while lifting the sub-frame to take the pressure off the screws, (screw counter-clockwise). Next, push in the Stabilisation Leg's spring-loaded press-stud and push the Leg fully back into the sub-frame.

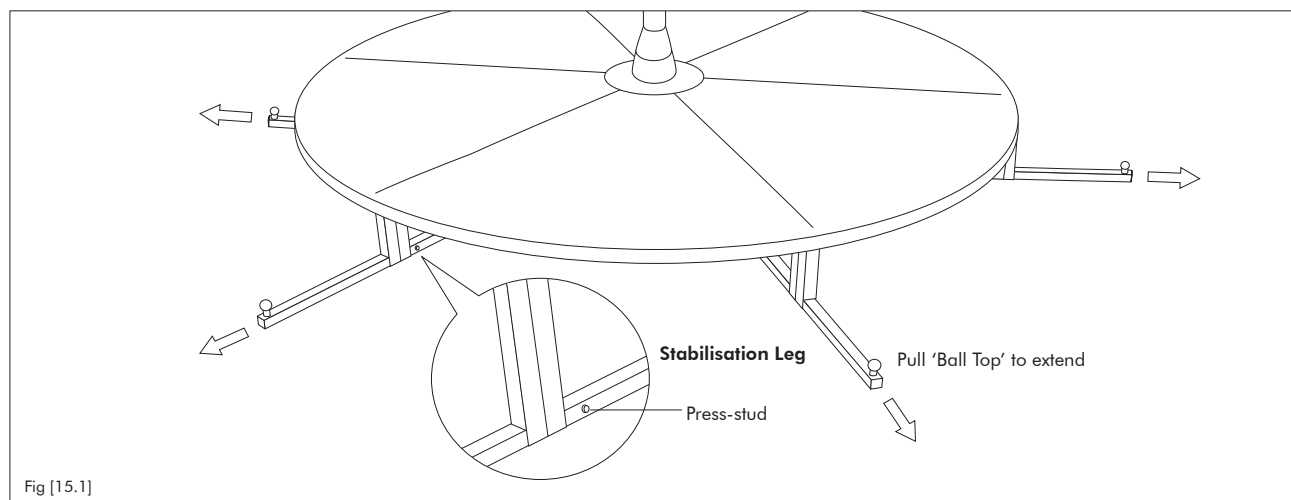

**CAUTION:** Please be careful when the stabilisation legs are extracted to make sure you don't trip over them. Highly recommended for executing aggressive moves or heavier persons. The X-STAGE is fine to be used without extracting the legs for normal use.

## MAIN STAGE - ADDITIONAL STABILISATION

The X-Stage/X-Stage Lite are very stable in its standard format and can be used for most spins and moves. However, if you intend to perform more aggressive moves or if the Stage is to be used by heavier persons, the built-in stabilising legs and/or additional weights should be used.

First remove one of the Floor Plates and locate the Weight Plate retaining caps on either Frame Leg (Fig.16.2) – completely unscrew the retaining caps and remove.

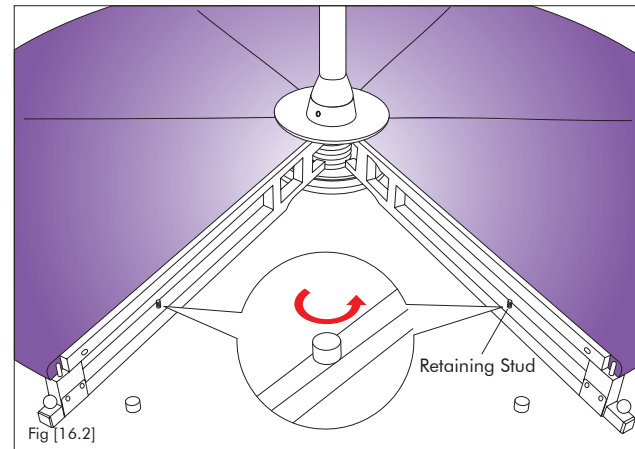
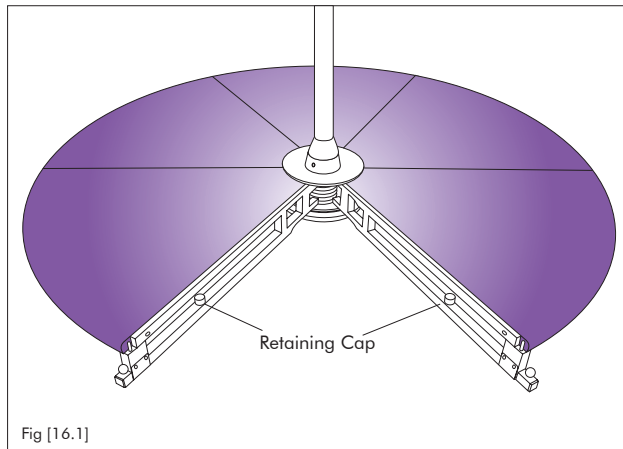

Place the Weight Plate over the locating screw studs (Fig.16.3). Once firmly in place, replace the Weight Plate Caps to fully fasten the Weight Plates in position. Once the weight plates are in situ, place optional sandbags (available from our website) or standard gym weights (10kg-30kg per section) onto the plate (Fig.16.4).

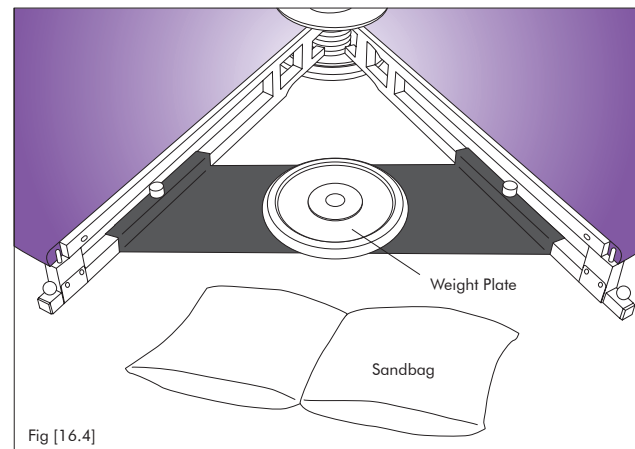
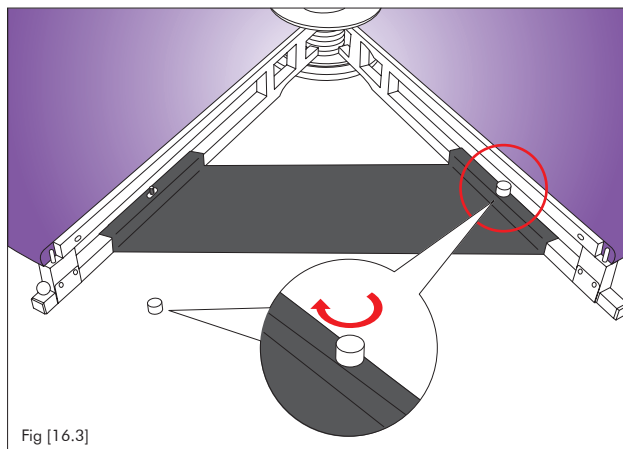

It is important to place the Weight Plates and the weights on alternating plates as displayed in (Fig.16.5). Once all the Weight Plates and weights have been correctly placed, replace all the Floor Plates and now your stage is ready for more demanding moves (Fig.16.6).

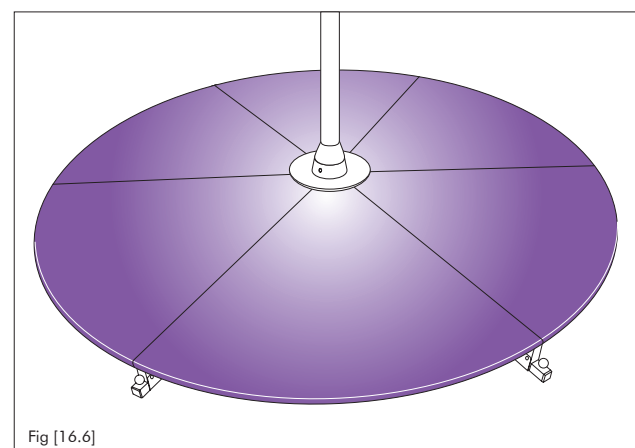
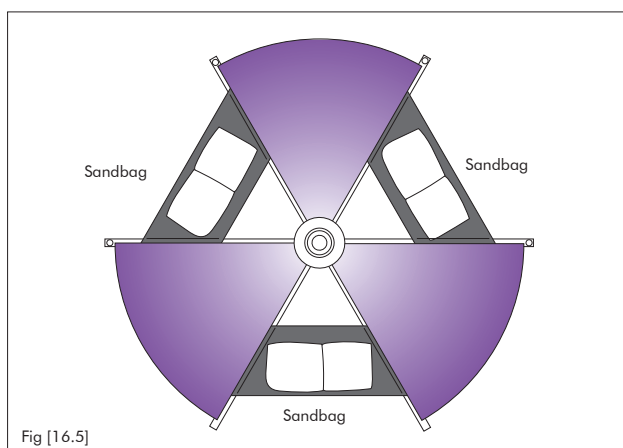



## Static/Spin Mode Function

To change from Static to Spin mode, using your 5mm hex key, tighten the two hex screws contained within the 'X' marked holes. To revert back to Spin mode, loosen the screws within the 'X' marked area. When removing your pole, you must ensure that the pole is placed in Static mode (screws tightened/locked) prior to removal.

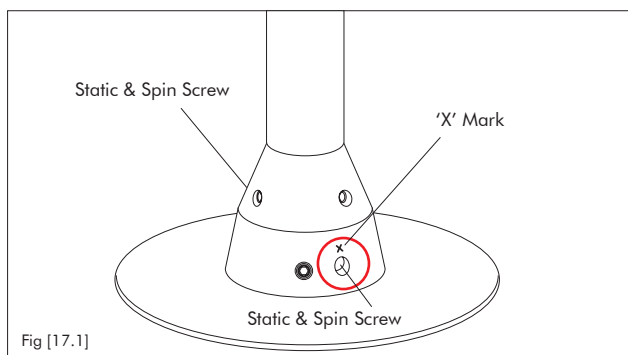

Fig [17.1]

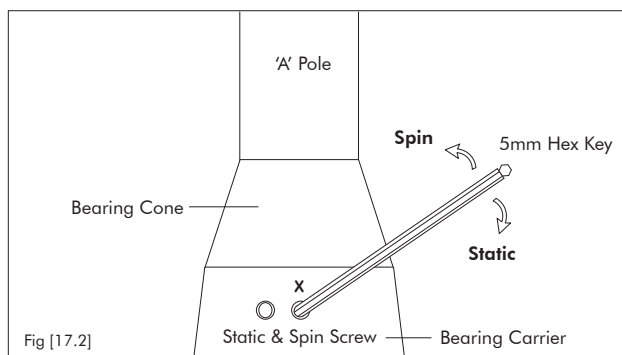

Fig [17.2]

## POLE MAINTENANCE

It is important to check that the X-Joint is completely fastened before every use and check the joints every half-an-hour. It is also advisable to check that the Pole Retaining Screws and Bearing Retaining Screws are fastened securely prior to every use.

**DO NOT STORE YOUR STAGE  
IN A COLD/DAMP PLACE**

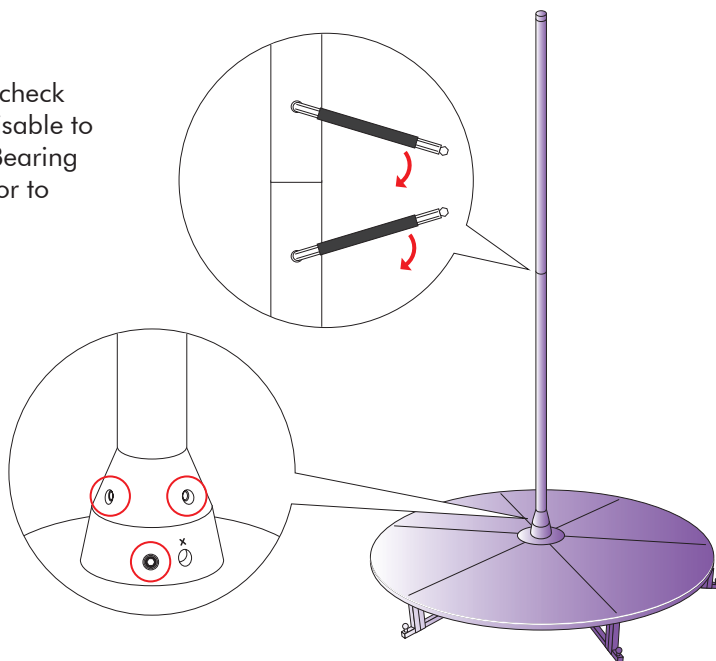

Fig [18.1]

## CLEANING YOUR XPERT POLE

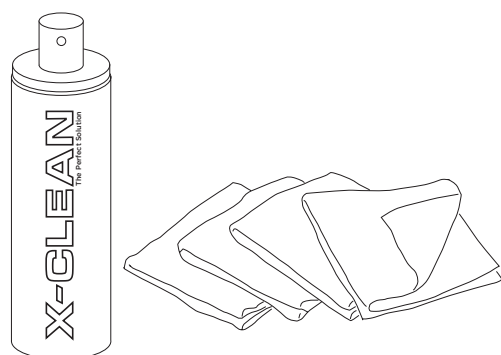

Fig [19.1]

### X-CLEAN & Micro-Fibre Cloths

X-POLE strongly recommends the use of X-CLEAN with our specially designed Micro-Fibre Cloths to clean and maintain the surface of your Pole. You can purchase these items from our website [www.xpole.com](http://www.xpole.com) (first select region, then search for X-CLEAN) or your Point of Purchase.

**DO NOT USE X-CLEAN on Powder Coated or Silicone Poles.**

## WARRANTY

This product has been manufactured and tested to the highest quality standards by X-POLE. This Limited Warranty offered by X-POLE covers defects in material or workmanship in new X-POLE products for a period of 6 months.

This warranty extends to the original purchaser only and is non-transferable. Only consumers purchasing X-POLE products from authorised X-POLE retailers or resellers or through the X-POLE website may obtain coverage under our limited warranties.

### **What is covered?**

X-POLE warrants this product against defects in material or workmanship as follows: X-POLE, at its own discretion, will replace at no charge for parts only or, at its option, replace any product or part of the product that proves defective because of improper workmanship and/or material, under normal installation, use, service and maintenance. If X-POLE is unable to provide a replacement and repair is not practical or cannot be made in a timely fashion, X-POLE may elect to refund the purchase price in exchange for the return of the product.

### **How Long Does The Coverage Last?**

Our warranty periods are 6 MONTHS from the documented date of purchase, depending on the type of product and where it was purchased. This does not affect your statutory rights.

### **What Our Warranty Does Not Cover?**

Our warranties do not cover any problem that is caused by:

- A. Conditions, malfunctions or damage not resulting from defects in material or workmanship.
- B. Conditions, malfunctions or damage resulting from (1) normal wear and tear, improper installation, improper maintenance, misuse, abuse, negligence, accident or alteration.
- C. Accessories, connected materials and products, or related products not manufactured by X-POLE.
- D. Defects from use, wear and tear, chipped edges from pole to pole contact or being dropped and anything outside of a pure manufacturing defect are not covered.

**Due to the high specification mirror finish, small tube surface blemishes or stress lines may be visible. These do not detract away from the quality of use of the pole and are only cosmetic issues.**

**POWDER COATED POLES ONLY: The Powder Coating is susceptible to damage if the pole is dropped or scratched in any way. When installing X-Joints/adding extensions, be careful not to damage the powder coating. DO NOT USE CHEMICAL BASED CLEANERS ON POWDER COATED POLES.**



# X-POLE<sup>®</sup> INTERNATIONAL

## **X-POLE UK & EUROPE**

Email: [sales@x-pole.co.uk](mailto:sales@x-pole.co.uk)  
Tel: +44 (0) 208 449 4400  
[www.x-pole.co.uk](http://www.x-pole.co.uk)

## **X-POLE USA**

Email: [info@xpoleus.com](mailto:info@xpoleus.com)  
Tel: +1 888 976 5387  
[www.xpoleus.com](http://www.xpoleus.com)

## **X-POLE Australia**

Email: [sales@x-pole.com.au](mailto:sales@x-pole.com.au)  
Tel: +61 (0) 2 9589 2645  
[www.x-pole.com.au](http://www.x-pole.com.au)

## **X-POLE Asia**

Email: [sales@x-pole.asia](mailto:sales@x-pole.asia)  
Tel: +86 (21) 6236 6090  
[www.xpolecn.com](http://www.xpolecn.com)

## **X-POLE Korea**

Email: [xpolekorea@hanmail.net](mailto:xpolekorea@hanmail.net)  
Tel: +82 (0) 32 277 5882  
[www.xpolekorea.kr](http://www.xpolekorea.kr)

## **X-POLE Russia**

Email: [i-conceptions@msn.com](mailto:i-conceptions@msn.com)  
Tel: +7 911 181 1277  
[www.i-conceptions.com](http://www.i-conceptions.com)

## **X-POLE South Africa**

Email: [sales@x-pole.co.za](mailto:sales@x-pole.co.za)  
Tel: +27 (0) 21 674 0074  
[www.x-pole.co.za](http://www.x-pole.co.za)

## **X-POLE New Zealand**

Email: [sales@x-pole.co.nz](mailto:sales@x-pole.co.nz)  
Tel: +64 (0) 9 528 0998  
[www.x-pole.co.nz](http://www.x-pole.co.nz)

